

2-PC. FLANGED END BALL VALVE NC2-HY

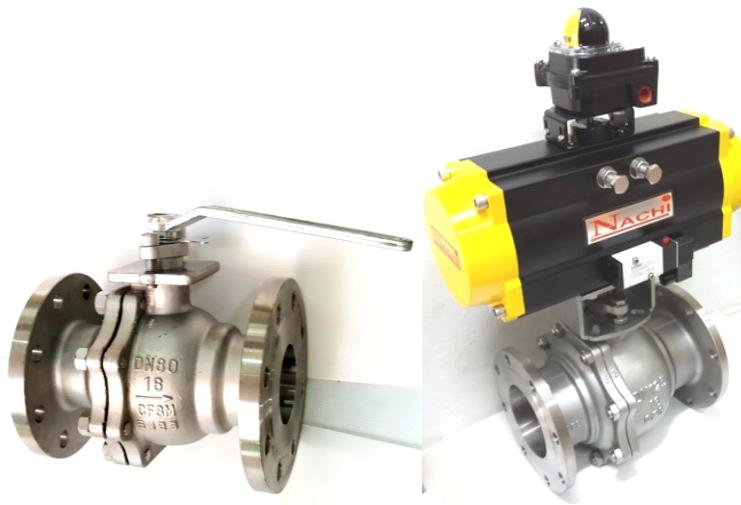

FEATURES

- Full port, 1/2"~12" (DN15~DN300)
- W.P. : CLASS 150/300
- W.T. : -20 C~200 C (-4 F~392 F)
- Investment casting
- Blow-out proof stem
- Anti-static device (option)
- ISO 5211 Mounting pad
- Flange dimension: ASME B16.5
- Face to face: ASME B16.10



OPTIONAL
Electro Positioner 4-20mA

ASTM A351-CF8 / AISI 304

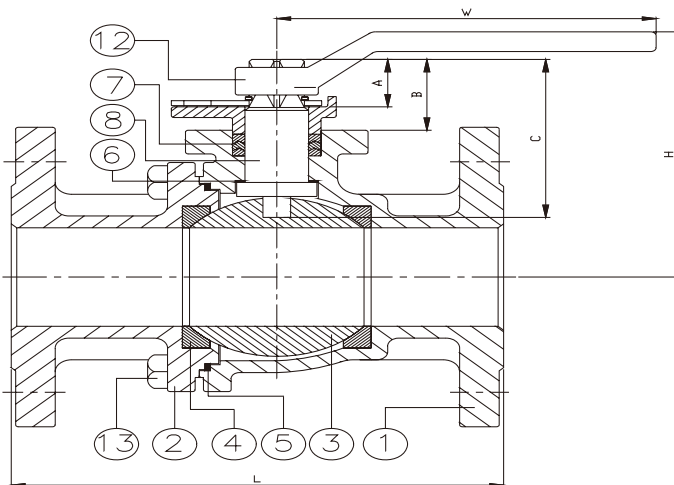

ITEM	PARTS	MATERIAL
1	BODY	STAINLESS STEEL
2	CAP	A351-CF8
3	BALL	AISI 304
4	SEAT	RTFE
5	SEAL	PTFE
6	THRUST WASHER	
7	PACKING	ASTM A276-316
8	STEM	
9	GLAND	ASTM A351-CF8M
10	LOCKING PAD	ASTM A276-316
11	GLAND BOLT	ASTM A276-316
12	HANDLE	ASTM A36(A536)
13	BOLT	ASTM A276-316

DN	L (Class150)	L (Class300)	H	W	PCD	M	A	B	C	Torque (N-M)	Weight (kg) (Class150)	Weight (kg) (Class300)	ACTUATOR MODEL
15	108	140	73	130	42	11	17.3	24.3	50	4	1.7	2.5	NC50
20	117	153	76	130	42	11	17.3	25.5	50	4	2	3.5	NC50
25	127	165	86	160	50	14	23.1	30.8	63.5	10	3	4.7	NC63
32	140	-	91	160	50	14	20.5	31	63.5	20	3.8	-	NC63
40	165	190	119	205	70	17	28.4	41.5	81	20	6	9.3	NC63
50	178	216	127	205	70	17	28.4	41	81	40	8.5	11.7	NC75
65	190	241	136	325	70	17	28.4	42.5	88	55	13.7	13.6	NC85
80	203	282	164	325	102	22	39.3	56	112	80	18.2	26.3	NC100
100	229	305	178	325	102	22	38.1	56	112	120	28	39.3	NC100

unit:mm